

AGD332

Sign Activation Radar



The AGD332 detector is a true ranging FMCW radar designed for OEM integration into Vehicle Actuated Sign (VAS) applications.

The 332 has taken the powerful feature rich experience from the low power AGD331. Operating in the 24GHz K-band, the 332 offers an accurate speed measurement while discriminating between advancing and receding traffic.

Technical advancements allow for extremely low power consumption while maintaining vehicle detection distances up to 180 metres.

- Extremely low power usage
- Ease of integration onto host signs
- Flexible radar configuration via RS232
- Adjustable range and speed configuration

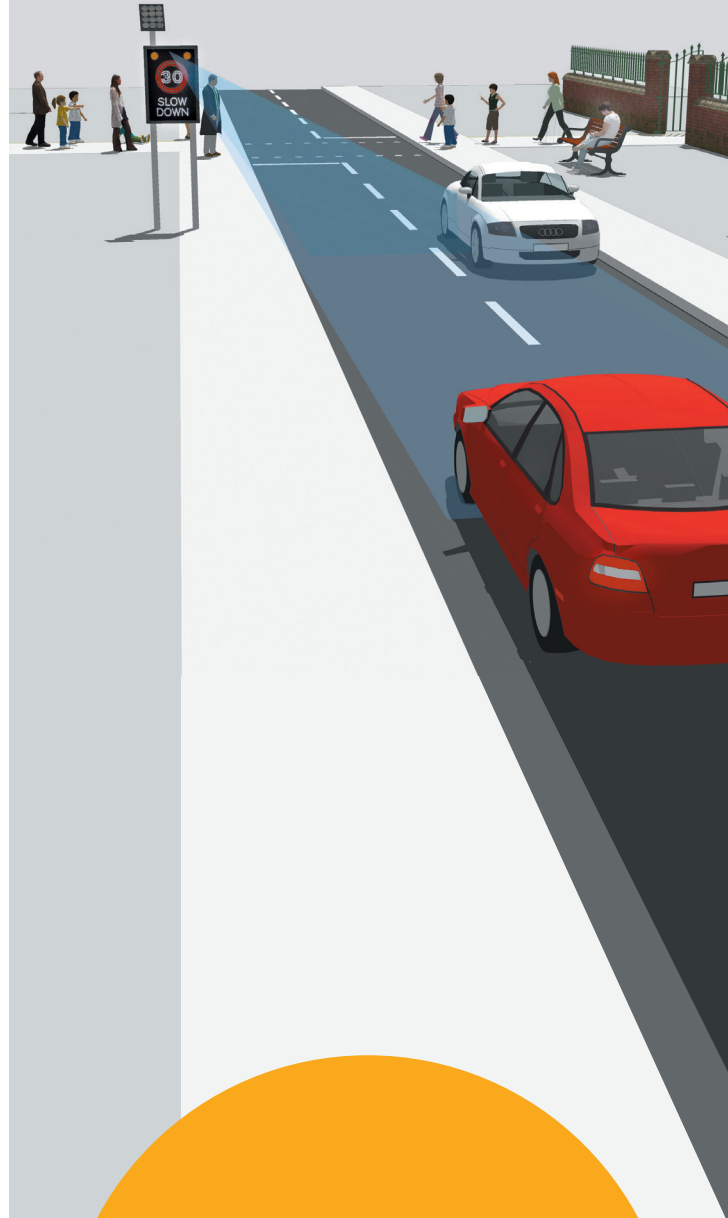

KEY FEATURES

- Target speeds reported based upon multiple configurable parameters
- Range to target up to 180 metres
- Speed measurement 11kph - 160kph (4kph - 160kph low speed mode)
- Bi-directional discrimination
- Dynamic frame rate for further reduction in power consumption (Patent pending)
- Low power design, 11.2mA @ 12Vdc (default dynamic frame rate)
- Two independent FET switched outputs
- RS232 serial communications for configuration and data output

AGD332

Sign Activation Radar

AGD LOW SPEED MODE

RS232 OPERATING MODE

A new operating mode has been introduced to allow the user to switch between the standard 11–160kph mode and a lower 4–160kph. Lower speeds may be required for industrial applications such as haulage routes or caravan parks where vehicles are required to travel below 10kph.

POWER CONSUMPTION

Changing the mode to allow the 332 to detect vehicles down at 4kph increases the power consumption to 27.8mA @ 12Vdc from 15.6mA.

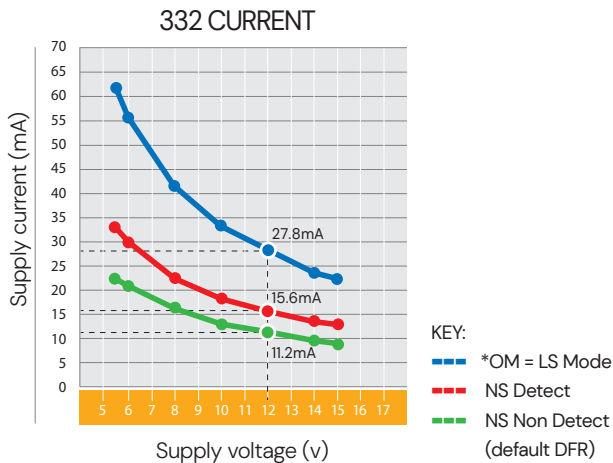
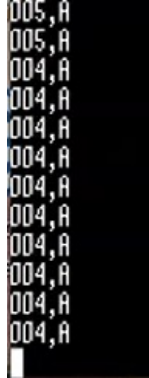

The AGD332 radar has taken the powerful feature rich experience from the low power AGD331. Using the latest power saving technology, the radar's design is a unique pulsed, frequency modulated transceiver linked to a 32bit ARM Cortex M4 processor. This helps deliver market leading radar performance while maintaining extremely low power usage.

PRODUCT SPECIFICATION

Technology	FMCW Doppler Radar
Frequency	24.2GHz / 24.125GHz (FCC)
Mounting Height	2–5m nominal (optimum 3m)
Range/Zone	Up to 180m (dependent on sign mounting and user selection)
Low Speed Threshold	11 to 160kph or 4 to 160kph (depending on the selected mode)
Direction	Advance / Recede / Bidirectional
Operating Temp	-20°C to +60°C
Power Supply	5.5/15Vdc
Current	Detect: 15.6mA nominal at 12Vdc Non Detect: 11.2mA nominal at 12Vdc Low Speed Mode: 27.8mA nominal @12Vdc
Housing Material	UV Stable Polycarbonate
Housing Finish	Self Coated Black
Detect Outputs	x2 FET Switched / x1 RS232
Weight	300g nominal
User Adjustments	Full configuration of all parameters via RS232
Approvals	EN 301 489, EN 50293, EN 300 440, FCC CFR47 Part 15.245, RSS-210, AS/NZS 4268

DIMENSIONS

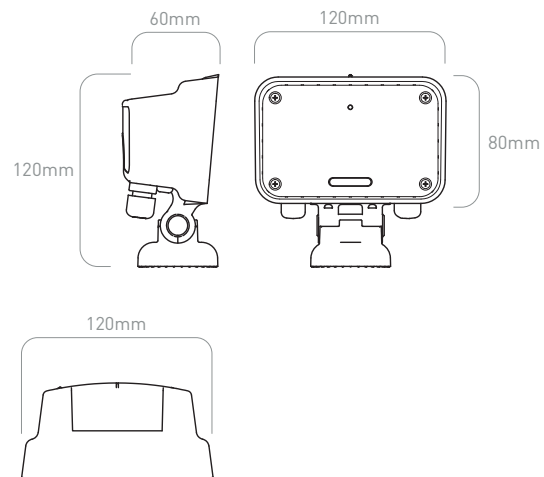

AGD® | SAFER
GREENER
MORE EFFICIENT

AGD Systems Limited
White Lion House, Gloucester Road
Cheltenham, GL51 0TF, UK

Tel: +44 (0) 1452 854212
Email: info@agd-systems.com
Web: agd-systems.com

TESTED AND AGD CERTIFIED

All AGD products are Tested, Calibrated and AGD Certified so customers know that all devices will perform exactly as described.